

1.0 ADVANTAGES OF THE BRIDGE CONNECTION

The bridge connection of two power op amps provide's output voltage swings twice that of one op amp. And it is the only way to obtain bipolar DC coupled drive in single supply applications. Two possible situations where this is an advantage would be in applications with low supply voltages, or applications that operate amplifiers near their maximum voltage ratings in which a single amplifier could not provide sufficient drive.

There are other incidental advantages of the bridge connection. It effectively doubles the slew rate, and non-linearities become symmetrical reducing second harmonic distortion in comparison to a single amplifier circuit.

2.0 BRIDGE CONCEPTS AND TERMINOLOGY

Figure 1 is a circuit diagram for the most common variation of a bridge connection using power op amps. To clarify the discussion of this circuit, we'll refer to the left hand amplifier A1 as the master amplifier, and A2 as the slave. The master amplifier accepts the input signal and provides the gain necessary to develop full output swing from the input signal. The total gain across the load will be twice the gain of the master amplifier.

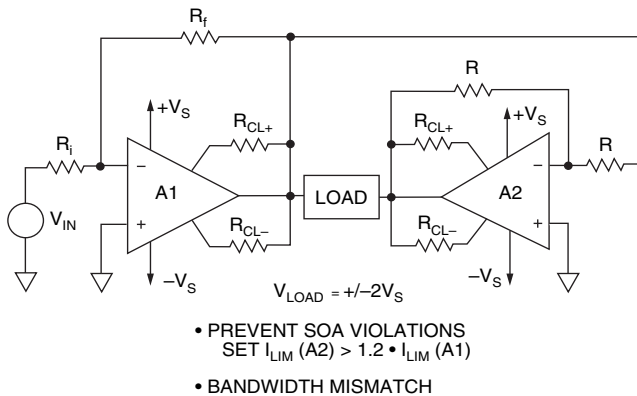

FIGURE 1. BRIDGE MODE WITH DUAL SUPPLIES (MASTER/SLAVE)

The master amplifier can be set up in virtually any op amp type circuit: inverting or non-inverting, differential amplifier, or as a current source such as an Improved Howland Current Pump.

Always configure the slave as a unity gain inverting amplifier and drive it from the output of the master. Later discussions in connection with Safe Operating Area (SOA) and protection will show the importance of this point.

3.0 PROTECTION AND SOA

In the following discussions that all general precautions in using power op amps, such as the need for external flyback diodes, transient protection, input protection, etc., must be addressed. These subjects are dealt with in "GENERAL OPERATING CONSIDERATIONS". The following discussion will concern itself only with specific protection issues related to bridge connections.

The concept of driving the slave from the output of the master power op amp is essential for proper protection. The best illustration of the value of that configuration is shown with

an example such as Figure 1 where op amps with adjustable external current limiting have been used. With externally settable current limit, set the master to current limit 20% lower than the slave. If the master cannot be reduced, then raise the slave 20% above the master to provide better overall protection than leaving them equal. If a fault occurs in the load such as a short across the load, this will cause the master to current limit and it's output will clip. Since the master is driving the slave, we are effectively clipping the drive to the slave also. Under these conditions the SOA voltage stress will be equally shared between the two amplifiers.

With op amps having fixed internal current limits it is impossible to insure that the master current limits first. This is not a total disaster, it just means that under load fault conditions it cannot be guaranteed that the amplifiers will share the SOA voltage stress, and it must be assumed that one amplifier could bear the entire stress.

Figure 2 is a simplification of output stages to give examples of amplifier stress under a difficult (low resistance such as a stalled DC motor) load condition. The worst case stress must be used where amplifier current limiting cannot be controlled. From this example it can be seen that proper setting of current limiting, when possible, can halve stresses under fault conditions.

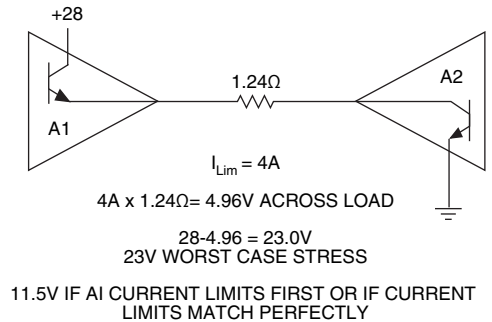

FIGURE 2. EVALUATION AGAINST SOA

Consider each amplifier individually for load analysis, SOA plotting and power dissipation calculations by halving the actual load impedance. Each individual amplifier cannot "see" the amplifier connected to the other end of the load. The other amplifier doubles the voltage, and thus the current, in the load.

4.0 STABILITY

4.1 STABILITY CONSIDERATIONS FOR THE SLAVE

Because the slave amplifier must operate as a unity gain inverter it will be the most critical with regards to stability. Stability enhancement methods invariably involve a tradeoff of frequency response. Fortunately, in the case of the bridge, the master amplifier bandwidth is naturally restricted by operating at higher gains (as well as easing stability considerations for the master). Usually the slave can be compensated such that the resultant circuit will have matching bandwidths on both halves.

Noise gain compensation is the favored method of enhancing stability. Keep in mind that noise gain compensation depends

on the non-inverting input being connected to a low impedance ($< 0.1R_n$). This is not a problem when the non-inverting input can be grounded, as in split supply applications, but it must be considered in single supply applications as the half supply voltage reference point must be a good AC ground. The simplest way to insure a good AC ground is by good bypassing in the form of a tantalum or electrolytic capacitor in parallel with a ceramic capacitor.

4.2 NOISE GAIN COMPENSATION

As shown in Figure 3, a simple way of visualizing the effect of noise-gain compensation is that it raises the apparent gain that the amplifier “sees” (or in other words, reduces feedback) while not affecting the actual signal gain. Select R_n such that $R_n > 0.1R_i$ to limit the phase shift added by the noise gain compensation. Note from the graph in Figure 3 that, in the example shown, the noise gain compensation introduces a pole in the feedback path. In this case, at approximately 300 Hz. At 3000 Hz there is a zero in the feedback path. The region between these points should be kept to less than a decade in frequency wide, and a maximum gain difference of 20 dB is implicit in that requirement. In short, noise gain for the slave (which has an uncompensated noise gain of 2, or 6 dB) must be ≤ 20 , or 26 dB.

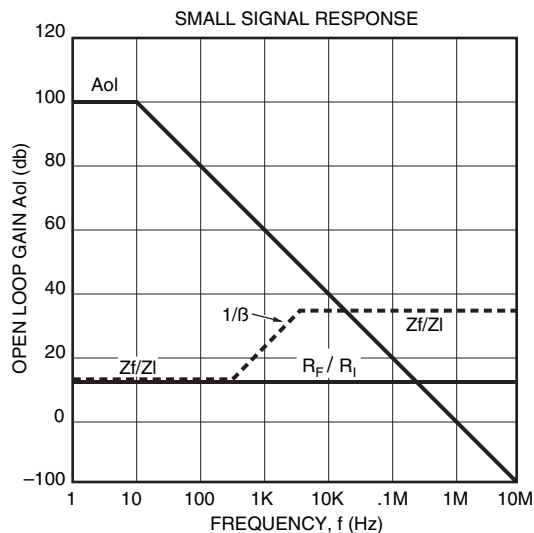
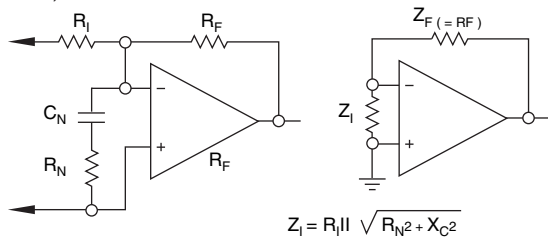

FIGURE 3. NOISE-GAIN COMPENSATION

Another consideration that could be given to the selection of R_n is in regard to frequency response (gain vs. frequency). From Figure 3, the signal gain of a circuit using noise gain compensation rolls off at the point where the noise gain intersects the amplifier A_{ol} . In the case of Figure 3, the normal bandwidth would be about 250 KHz, with compensation about 25 KHz. Without compensation, the slave would have wider bandwidth than the master which is operated at higher gains.

An ideal value for R_n would be one which makes the noise gain of the slave match the signal gain of the master, assuming there is not greater than 20 dB of difference, and the

noise gain limit of 26 dB in the slave is not exceeded. In the event the master will also require noise gain compensation for stability, the same principle of matching the noise gain will help to insure matched bandwidths.

$$V_N = \frac{1}{2\pi \cdot F \cdot R_N}$$

The upper corner frequency of the noise gain compensation, or zero, is determined by C_n such that :

where F = desired zero frequency. C_n should be selected so that the zero is lower than one-tenth the frequency where the high frequency noise gain crosses the A_{ol} .

4.3 STABILITY CONSIDERATIONS FOR THE MASTER

In the case of the master, as well as the slave, capacitive loads should also be considered. The only time the master would need noise gain compensation would be for very low gains, capacitive loading, or when using amplifiers with minimal phase margin such as the PA10 and PA12. Methods of analysis for capacitive loads are discussed in detail in “STABILITY FOR POWER OP AMPS”, Application Note 19.

Amplifiers with emitter follower or source follower outputs generally do not have problems with inductive loads. However, collector or drain output amplifiers such as the PA19, PA03 and especially the PA02, with it’s local feedback loop in the output stage, can oscillate into inductive loads. Monolithic amplifiers with quasi-complementary output stages can also be sensitive to inductive loading. Compensate these amplifiers with a series R-C “snubber” from each amplifier output to ground. For power amplifiers the resistors typically run 1 to 10 ohms and capacitors 0.1 to 1.0 μF .

5.0 SPECIAL CASES OF THE BRIDGE CONNECTION

5.1 CURRENT OUTPUT

The bridge connection can be a useful tool in a current output circuit. The maximum rate-of-change of current in an inductor, as would be used in a deflection application, is a function of available voltage. For that reason the bridge circuit could double the speed of a magnetic deflection application.

In a current source configuration, the slave remains as an inverting voltage amplifier. Only one amplifier needs to be (or should be) a current source. Of the available ways of configuring an op amp for current output, only the Improved Howland Current Pump is practical for a power op amp bridge.

In Figure 4, the master amplifier is configured as the current pump. R_8 is the current sensing resistor. The Improved Howland Current Pump has many special considerations which will not

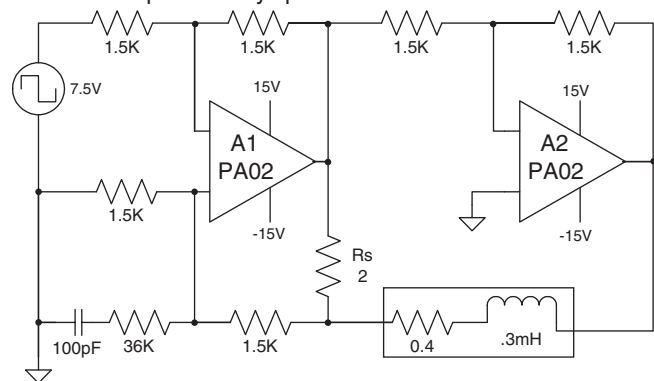

FIGURE 4. ELECTRO-MAGNETIC DEFLECTION (BRIDGE AMPLIFIER)

be discussed here, but it will suffice to say that generally the feedback and input resistors should be very closely matched,

usually better than 0.1%.

For details on voltage and current waveforms of this circuit, refer to Applications Note 5, Precision Magnetic Deflection.

5.2 UNIPOLAR OUTPUT

A particularly powerful way of applying the bridge is in the unipolar bridge. By unipolar, we mean that the output can only swing from 0 to one polarity. Figure 5 is used to illustrate this technique.

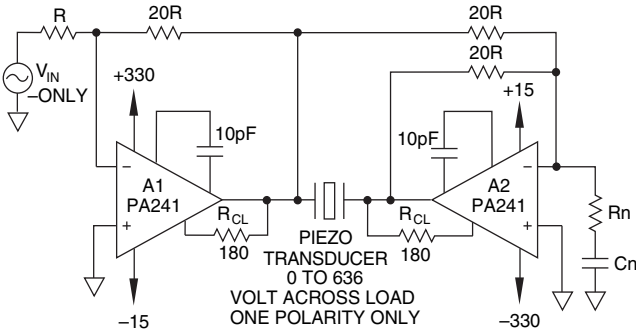

FIGURE 5.

The master is a PA241 operating on supply rails of +330 and -15 volts. The slave is operated at +15 and -330 volts. The lower voltage supplies need only be large enough to respect the linear COMMON MODE voltage range requirements of whatever amplifier is used (14 volts in the case of the PA241).

The circuit is designed to accommodate positive going inputs only. At full output swing the master can reach +318 volts while at the same time the slave is at -318 volts for a total voltage across the load of 636 volts. The full dynamic range with regard to the load is 0 to 636 volts unipolar.

The circuit could also be designed such that it accepts negative going inputs and the output of the master swings negative and the slave positive by reversing the supplies.

5.3 SINGLE SUPPLY APPLICATIONS

In the single supply circuit shown in Figure 6, connect the slave's non-inverting input to a pair of equal value resistors connected between supply and ground. This provides a 1/2 supply center operating point for the entire bridge. This point should be well bypassed.

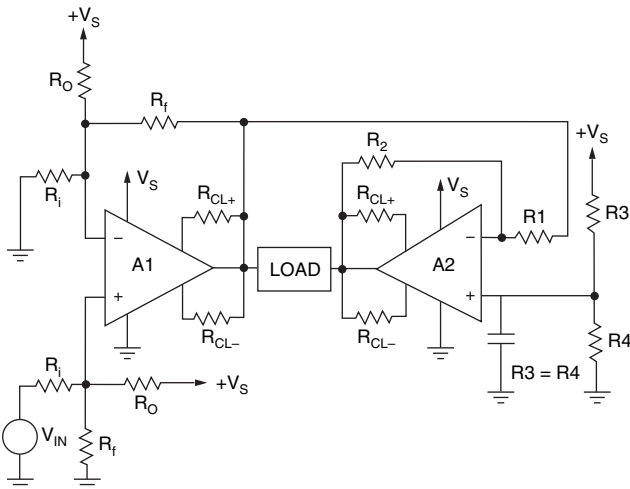

FIGURE 6. BRIDGE MODE WITH SINGLE SUPPLY (OTHER THAN PA21)

The simplest way to understand the configuration for the master is to delete the resistors R_o , upon which the master becomes the standard circuit for a differential amplifier. The two R_f resistors should be reasonably matched to each other, and the two R_i resistors matched to each other. An advantage of this configuration is that the gain is simply the ratio of R_f/R_i .

Now consider the R_o resistors. Their sole purpose is to provide an equal DC bias on each input and to get the quiescent DC level within the amplifiers COMMON MODE voltage range requirements. This is generally anywhere from 5 to 12 volts inside of each supply rail and is given on all amplifier data sheets. For example, using PA05 on a 90 volt supply, the COMMON MODE VOLTAGE RANGE of the PA05 dictates that the inputs must never come closer than within 8 volts of either rail. So the objective is to select R_o , to set the amplifier inputs to at least 8 but not more than 82 volts, and to stay within these limits under normal input swings. As far as exactly what voltage? It could be argued that half supply is the optimum common-mode point assuming this doesn't cause excessive current to flow in the R_i resistors. In higher voltage applications the range of 5 to 15 volts is more practical though. The PA75 is especially easy to use in single supply applications. Since these amplifiers common-mode range includes the negative rail, or ground, their inputs can be driven directly without additional biasing components. The slave must still have its noninverting input biased at 1/2 supply for proper bridge operation.

5.4 PARALLEL CONNECTION

The bridge circuit can also be combined with the parallel connection of power op amps. Figure 7 shows how substantial audio power outputs can be obtained along with improved reliability since the parallel connection spreads the load among more amplifiers.

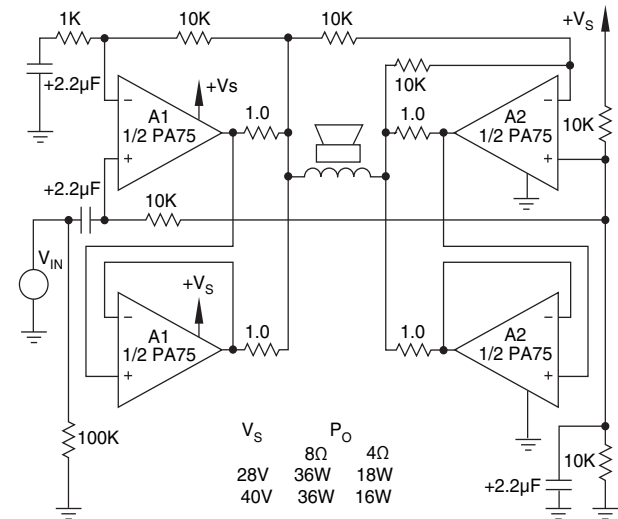

FIGURE 7. SINGLE SUPPLY PARALLEL BRIDGE

Note that in the parallel connection, the pair of paralleled amplifiers are labeled as master and slave also. Because the slave amplifier operates as a unity gain buffer, an amplifier must be selected which has a COMMON MODE voltage range that exceeds its output voltage swing capability. If this cannot be done, configure the slave as a differential amplifier with 4 equal valued and closely matched resistors.

Stability can also be a problem with the slave in the parallel amplifier. A resistor may have to be inserted in the feedback to allow for the use of noise gain compensation. (Noise gain

compensation does absolutely nothing when placed across the inputs of a unity gain buffer with no series resistance in the feedback path)

5.5 BRIDGES USING POWER BOOSTERS

A bridge circuit using the PB50 or PB58 would require a composite amplifier for both master and slave. The composite

amplifier is not an optimum configuration to operate at unity gain when stability is considered. Use noise gain compensation to establish an adequately high noise gain at high frequencies. Note that observing the criteria previously discussed regarding noise gain would typically dictate that the noise gain for the slave be ≤ 26 dB (Gain = 20). See Figure 8 for a bridge circuit using power boosters.

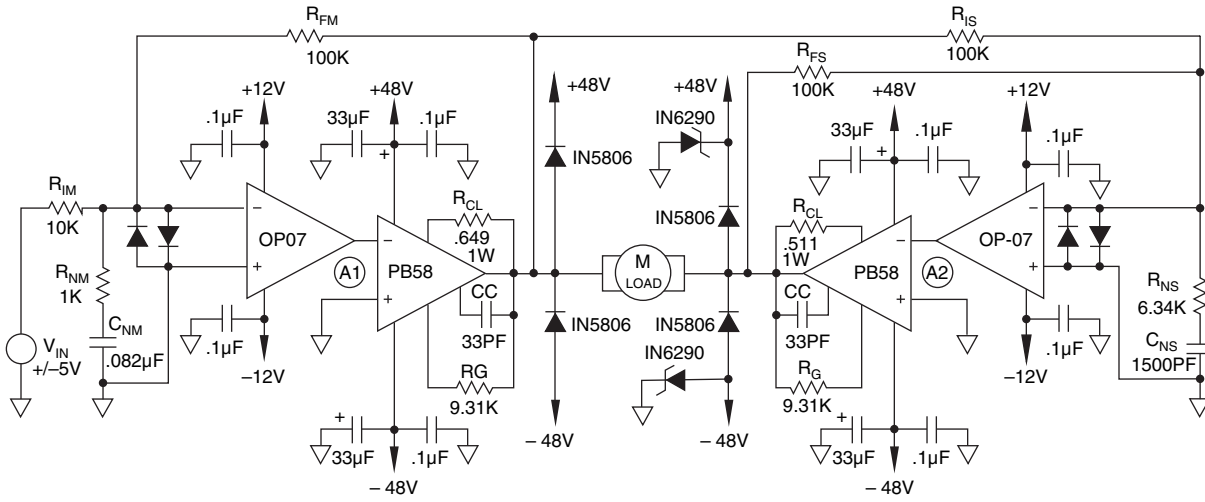

FIGURE 8. PB58A MOTOR DRIVE BRIDGE